

JENVEY

TC twin throttle body

© Jenvey Dynamics Ltd 2000-2010
Issue 2
www.jenvey.co.uk

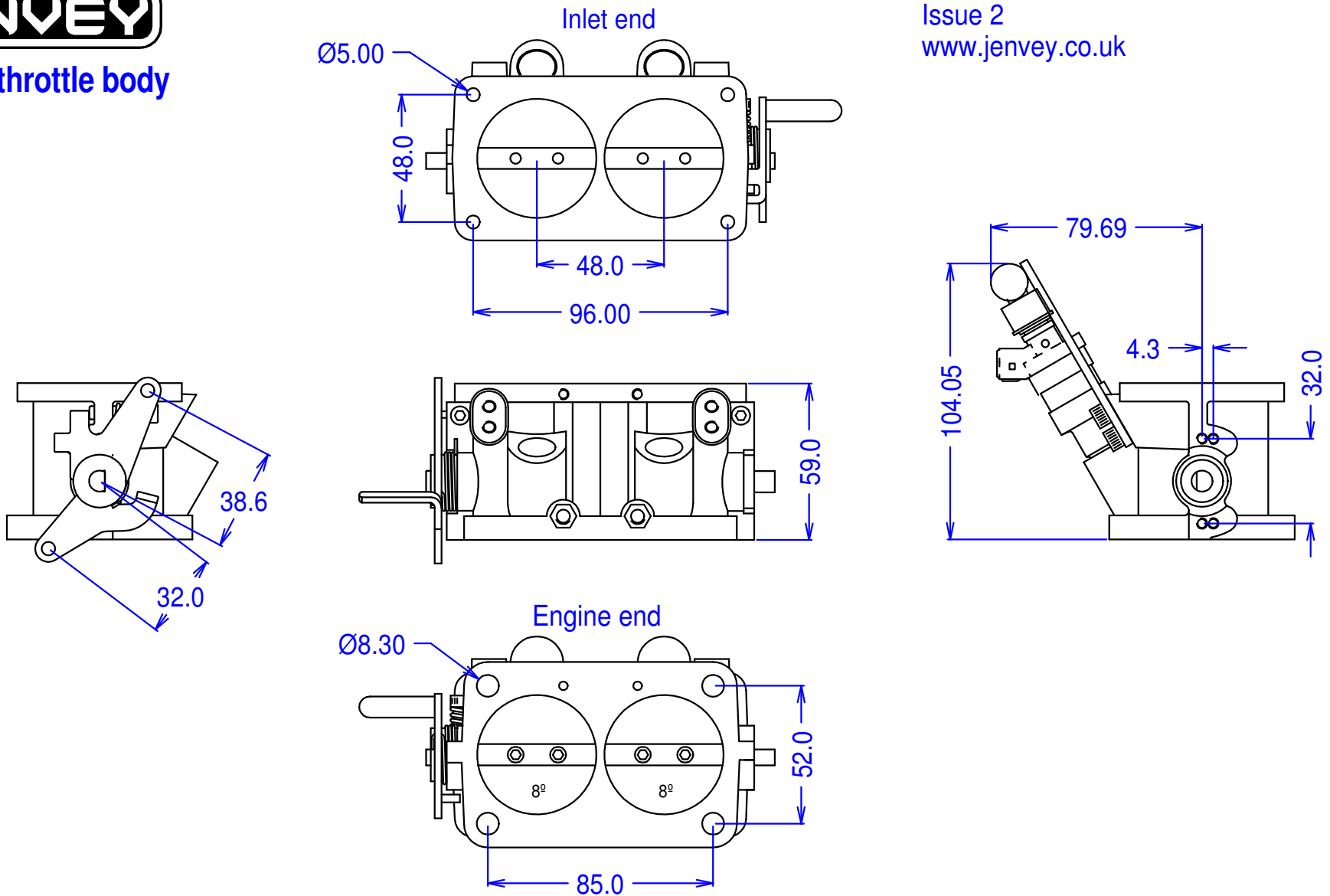

The TC body is designed to fit the same flanges as twin downdraft DCNF carburetors from Weber. It is a compact body, well suited for use on 'V' engines with their tendency to long inlet tracts and shortage of space.

The body comes with idle bypass adjustment, interconnecting link and fuel rails.

Operating data; Spindle rotation: 82 degrees. Torque per spindle at WOT: 300 - 340 N-mm which gives a tangential pull of 8 - 9 N on long arm of standard lever. Option of 115 N-mm springs available.