

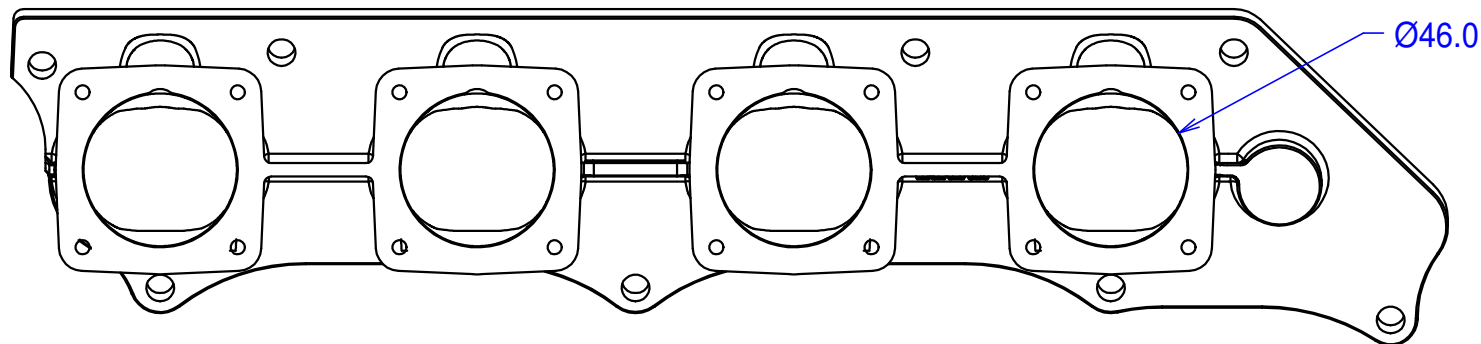

© Jenvey Dynamics Ltd 2000-2010
Issue 2
www.jenvey.co.uk

MH08 - Honda K20 FD2 manifold for individual throttle bodies

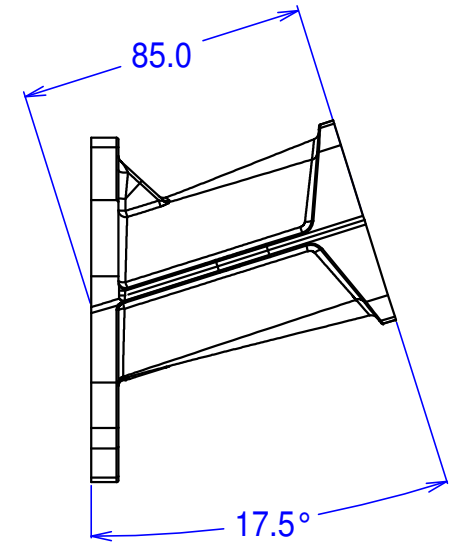
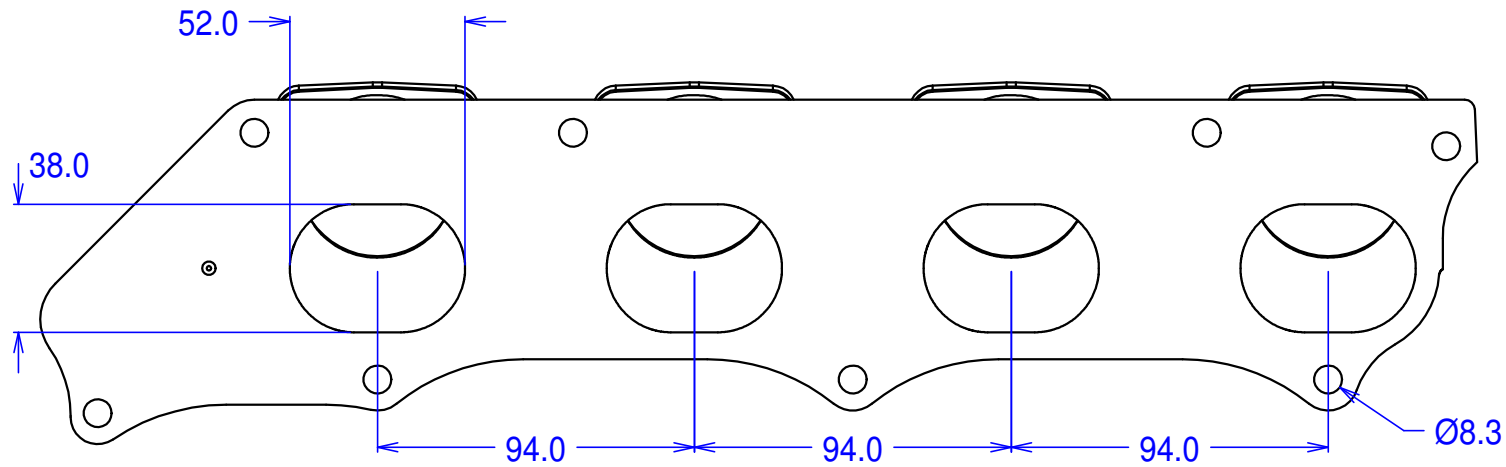

Flanges for Jenvey SF throttle bodies. May be ported out to 52mm at body flange and proportionally at head flange.
Undrilled bosses on top side for injector ports, vacuum tappings etc.
Undrilled bosses on underside for vacuum tappings.
Undrilled water tapping boss on head flange with drill starter point.