

Ref	Quant	Description
1	1	Mounting bracket (varies with type) To be purchased separately
2	1	Main frame
3	1	Quadrant
4	1	Spring mandrel
5	1	Cable and spring anchor block
6	1	Spring
7	1	Cable adjuster screw & locknut
8	2	Ball joint
9	1	Clevis pin
10	2	M5 x 30 bolt
11	1	M5 x 25 bolt
12	2	M5 x 12 bolt
13	1	M5 washer, 12.5mm OD (large)
14	1	'R' pin
15	1	Cable
16	4	M5 washer (small)
17	7	M5 stiffnut
18	1	8x14x5 Bush
19	1	3mm M5 Spacer

Parts may be mirrored or moved to the opposite sides of their mountings to change the axial position of the final output.

Ensure that the spring mandrel is running perpendicular to the anchor block. If not, the anchor block is probably the wrong way round!

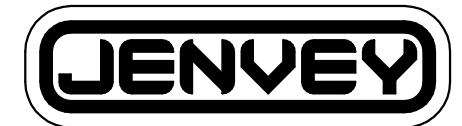

Linkage kit - CLS1

V4 - 10.16

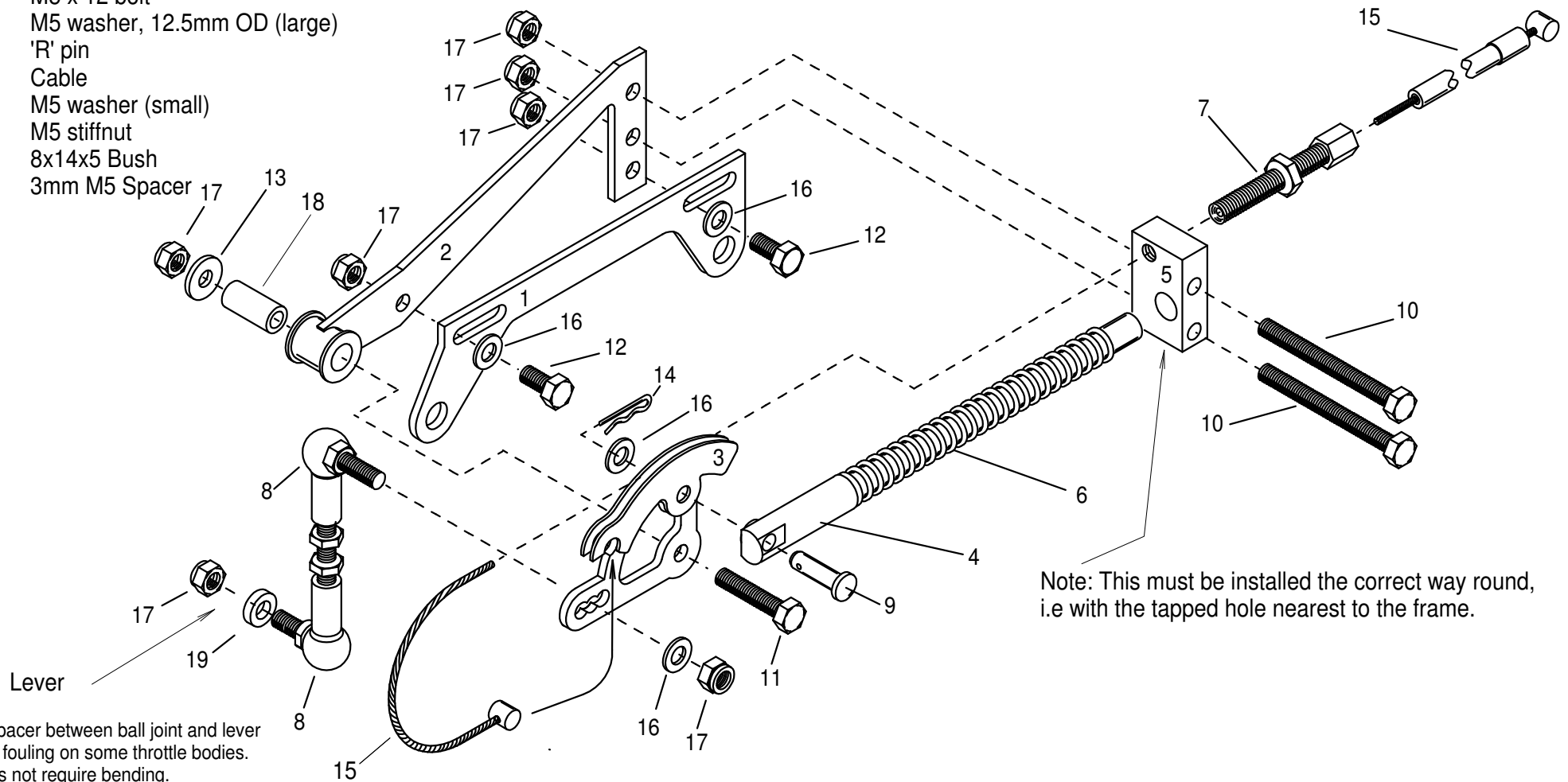

Fit 3mm spacer between ball joint and lever to prevent fouling on some throttle bodies. Lever does not require bending.

Note: This must be installed the correct way round, i.e. with the tapped hole nearest to the frame.